



Standard Waveguide Detectors

145 - 220 GHz



QR code



Hangzhou Multipath Electronics Co., Ltd., Zhejiang, China

Company Profile

Hangzhou Multipath Electronics Co., Ltd. is a high-tech enterprise specializing in the research, production and sales of various high-performance standard gain horns, waveguide probes, transparent antennas, MIMO antennas for communication, and phased array radar antennas. The products cover various types of waveguide arrays, patch arrays, dipole arrays, and ultra-wideband angle scanning arrays, and the frequency range covers low frequency to millimeter waves. The founding team of the company has been deeply involved in the field of electromagnetic array structures for many years and has rich experience in array antenna design. The team first applied the principle of bionics to electromagnetic wave control, and the original wideband angle scanning, low loss, and high precision technology is at the leading level internationally, and related technologies have been applied in many large projects. The founding members currently have more than ten core invention patents in this field, and have published many SCI journal papers.

Hangzhou Multipath Electronics will be dedicated to the research of cutting-edge electromagnetic field technology, to be a leader in antenna arrays, to tap the potential of electromagnetic fields, and to contribute to the development of science and technology.

⚙️ Product specifications

Part number	WD-WR5	Polarization	Single linear
Antenna type	Waveguide detector	Gain [dBi]	6 Typ.
Frequency range [GHz]	145 – 220	3dB beamwidth [deg]	E-plane: 100 Typ. H-plane: 70 Typ.
Waveguide band	WR5	Cross-polarization isolation [dB]	30 Typ.
Dimensions (H x W x L) [mm; inch]	19.05 x 19.05 x 50.00; 0.75 x 0.75 x 1.97	VSWR	1.5 Typ.
Weight (approx.) [kg; lb]	0.01; 0.022	RF connector	UG-387/U-M
Material	Cu (Gold plated)		

• Dimensional drawing: detectors, WD-WR5

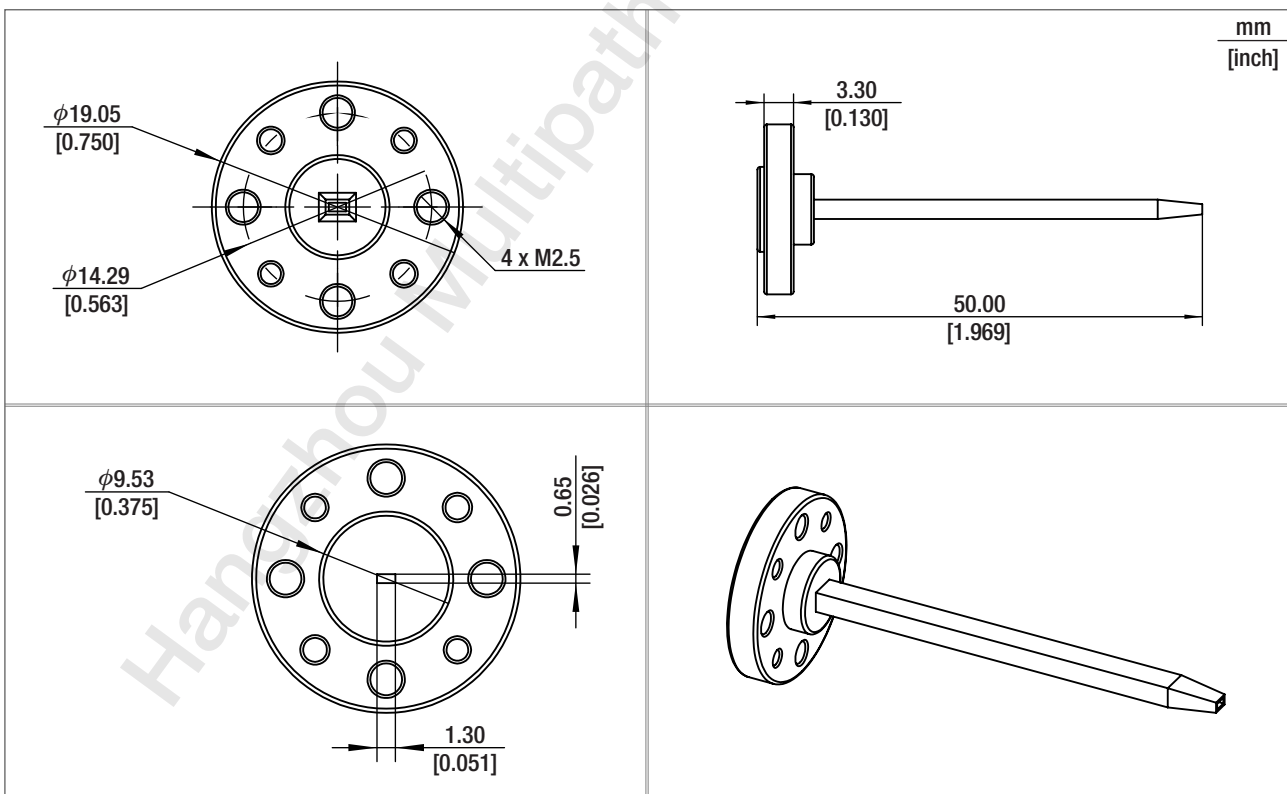

Electrical characteristics

Gain & Antenna factor & Cross-polarization isolation & VSWR

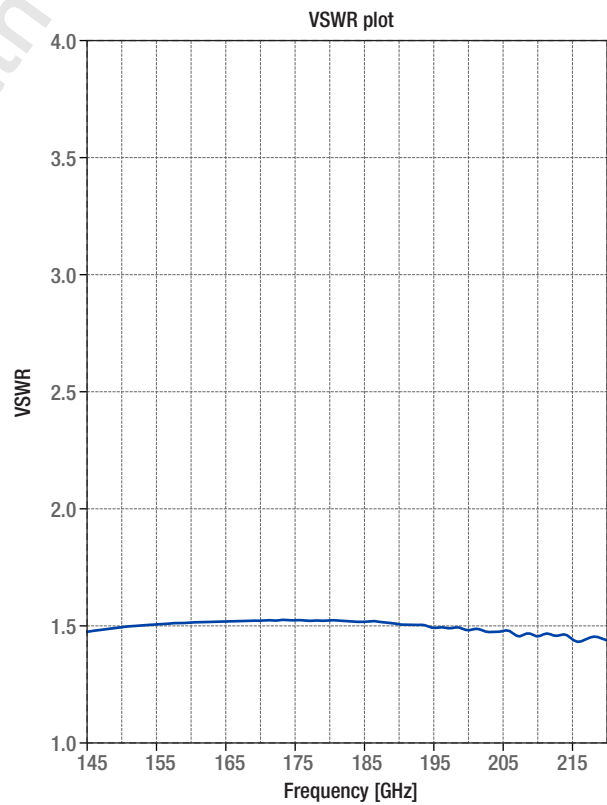
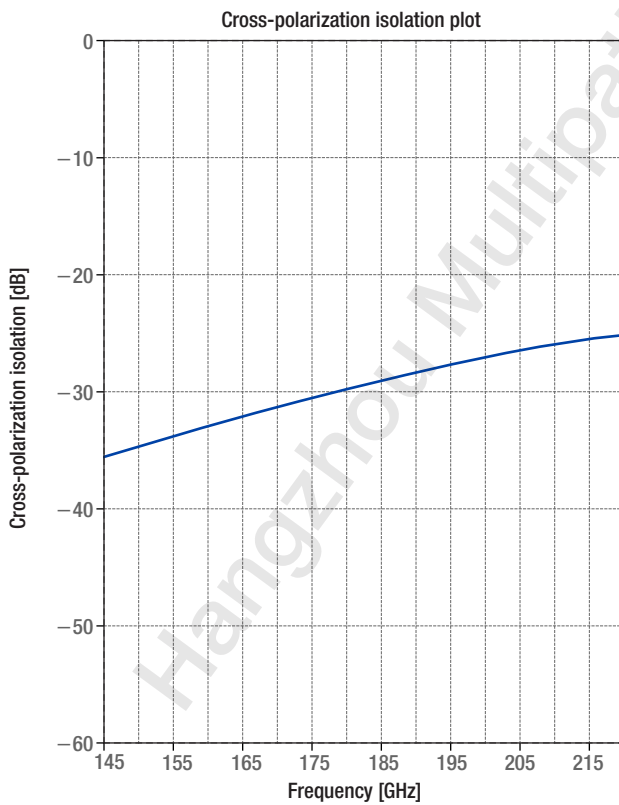
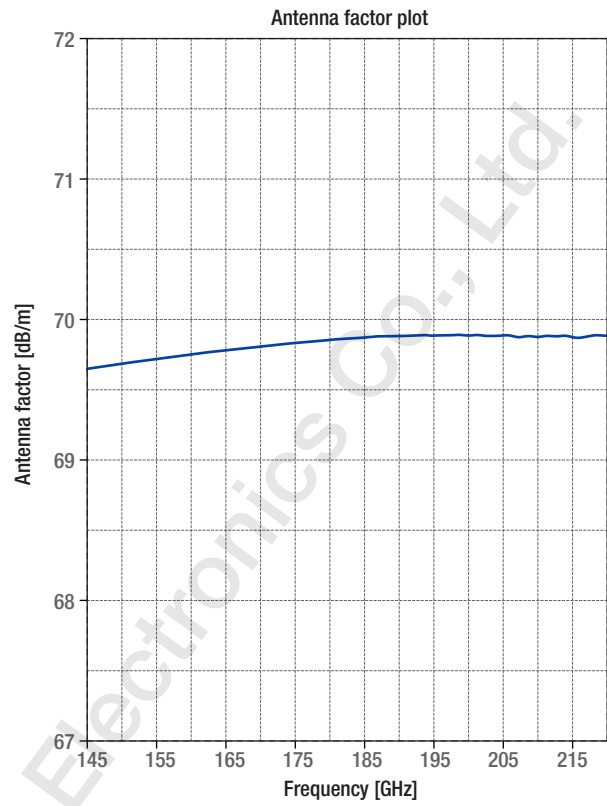
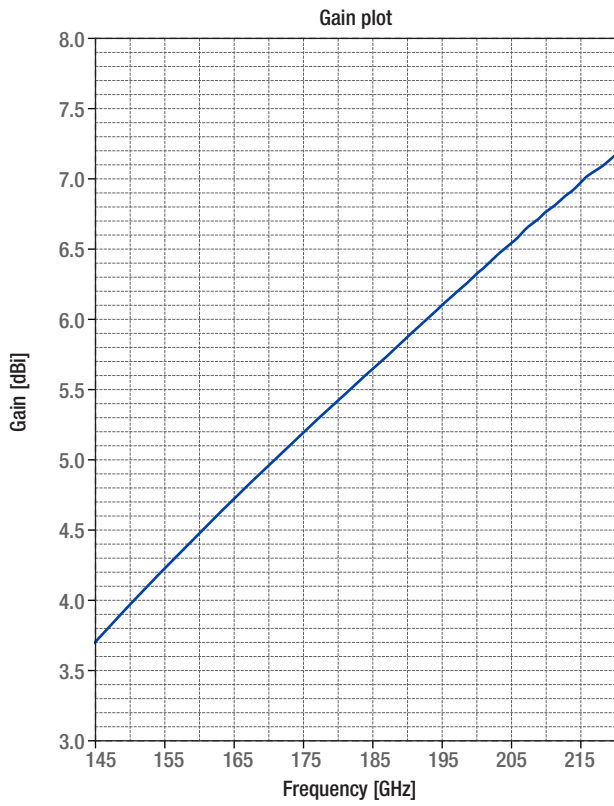

• Radiation patterns

Patterns @ 145 GHz

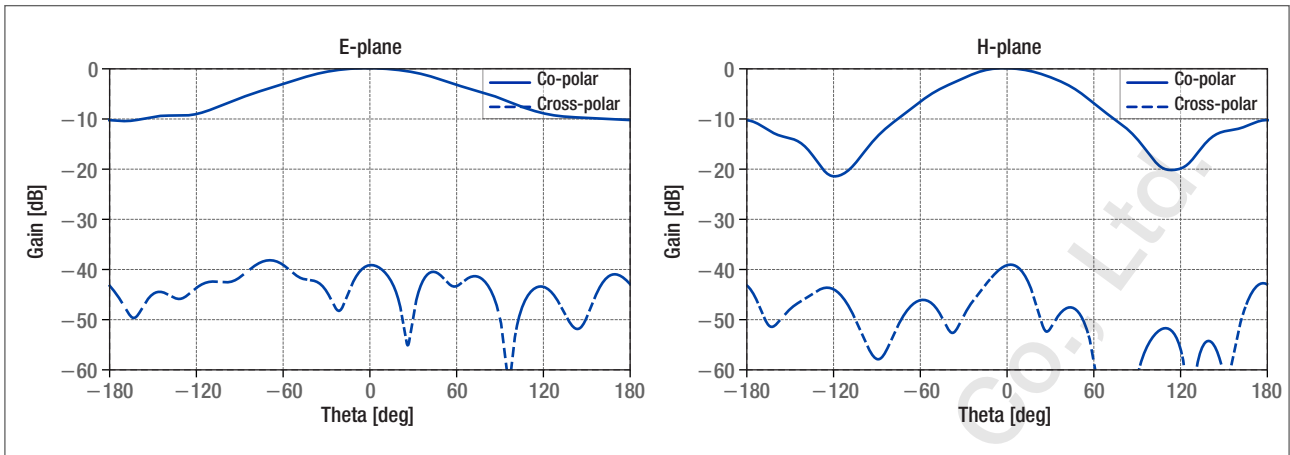

Patterns @ 182 GHz

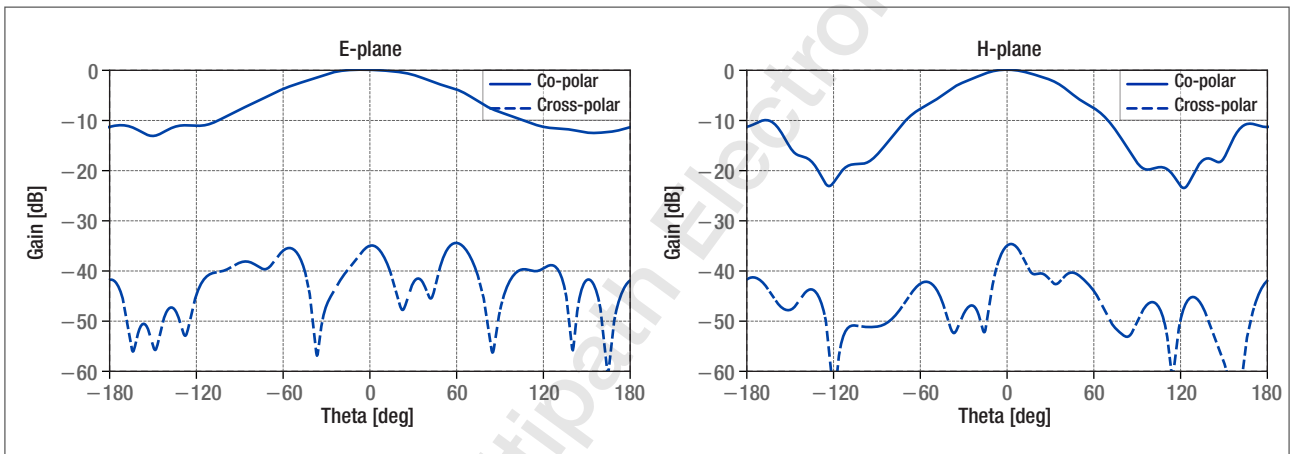

Patterns @ 220 GHz

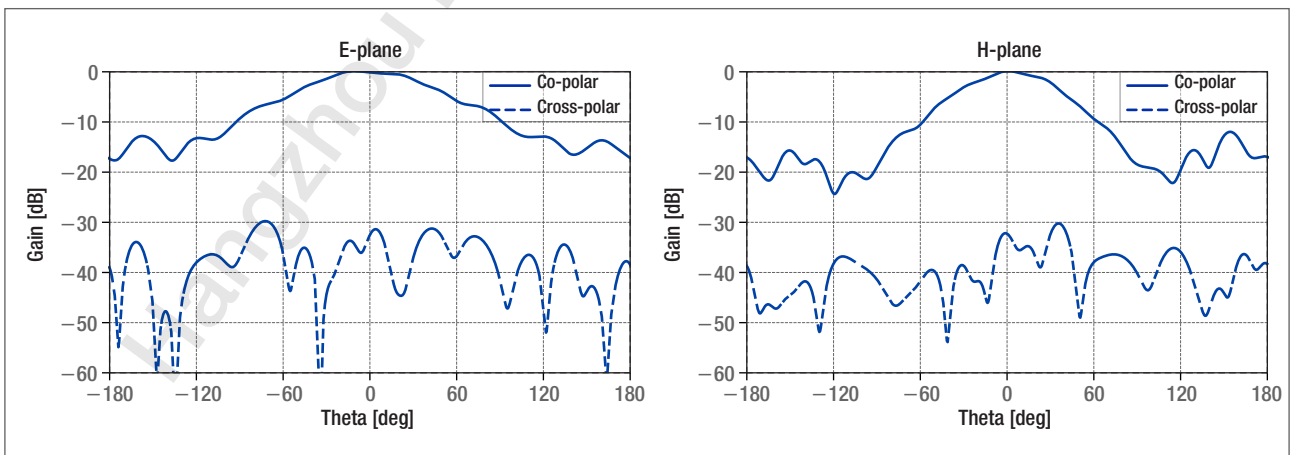

• Data table

Frequency [GHz]	Gain [dBi]	Antenna factor [dB/m]	Cross-polarization isolation [dB]	VSWR
145	3.75	69.66	-35.28	1.48
148	3.91	69.68	-34.76	1.49
151	4.06	69.71	-34.24	1.50
154	4.21	69.73	-33.72	1.51
157	4.36	69.75	-33.21	1.51
160	4.51	69.76	-32.71	1.51
163	4.65	69.78	-32.22	1.52
166	4.80	69.80	-31.74	1.52
169	4.93	69.81	-31.27	1.52
172	5.07	69.83	-30.81	1.52
175	5.21	69.84	-30.36	1.52
178	5.34	69.85	-29.91	1.52
181	5.48	69.87	-29.48	1.52
184	5.61	69.88	-29.06	1.52
187	5.74	69.89	-28.64	1.52
190	5.87	69.89	-28.23	1.51
193	6.01	69.90	-27.83	1.50
196	6.14	69.89	-27.44	1.49
199	6.27	69.90	-27.07	1.49
202	6.40	69.90	-26.71	1.49
205	6.53	69.89	-26.37	1.47
208	6.67	69.88	-26.04	1.45
211	6.79	69.89	-25.75	1.46
214	6.91	69.89	-25.49	1.46
217	7.04	69.88	-25.24	1.43
220	7.14	69.89	-25.05	1.45

Frequency [GHz]	E-plane, 3dB beamwidth	H-plane, 3dB beamwidth
145	114.69°	77.65°
182	101.48°	70.29°
220	84.45°	62.07°



Multipath Electronics

Contact

+86-571-56201039

sales@multipath.cn

https://www.multipath-electron.com

Technical specifications in this datasheet are subject to change without notice. Actual products may differ from the shown images.