

Broadband Horn Antennas

0.35 - 2.0 GHz, 10 dBi

Radiation pattern

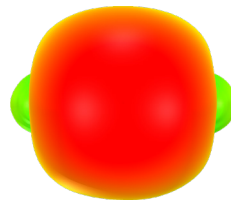

QR code



Hangzhou Multipath Electronics Co., Ltd., Zhejiang, China

⚙️ Product specifications

Part number	BDHA-0352-10	Polarization	Dual Linear
Antenna type	Quad-ridge horn	Gain [dBi]	10 Typ.
Frequency range [GHz]	0.35 - 2.0	Cross-polarization isolation [dB]	60 Typ.
Waveguide band	BDHA-0352-10	VSWR	2.00 Typ.
Dimensions (H x W x L) [mm; inch]	500.0 x 550.0 x 540.0; 19.69 x 19.69 x 21.26	Impedance [Ohms]	50
Weight (approx.) [kg; lb]	7.97; 17.571	RF connector	N-Female
Material	Aluminum	Port Isolation [dB]	60 Typ.

 Outline dimensions

Multipath Electronics provides complete broadband horn antenna, forming mounting systems, integrated with waveguide to coaxial adapters, L type mounting brackets.

• Assembly dimensional drawing

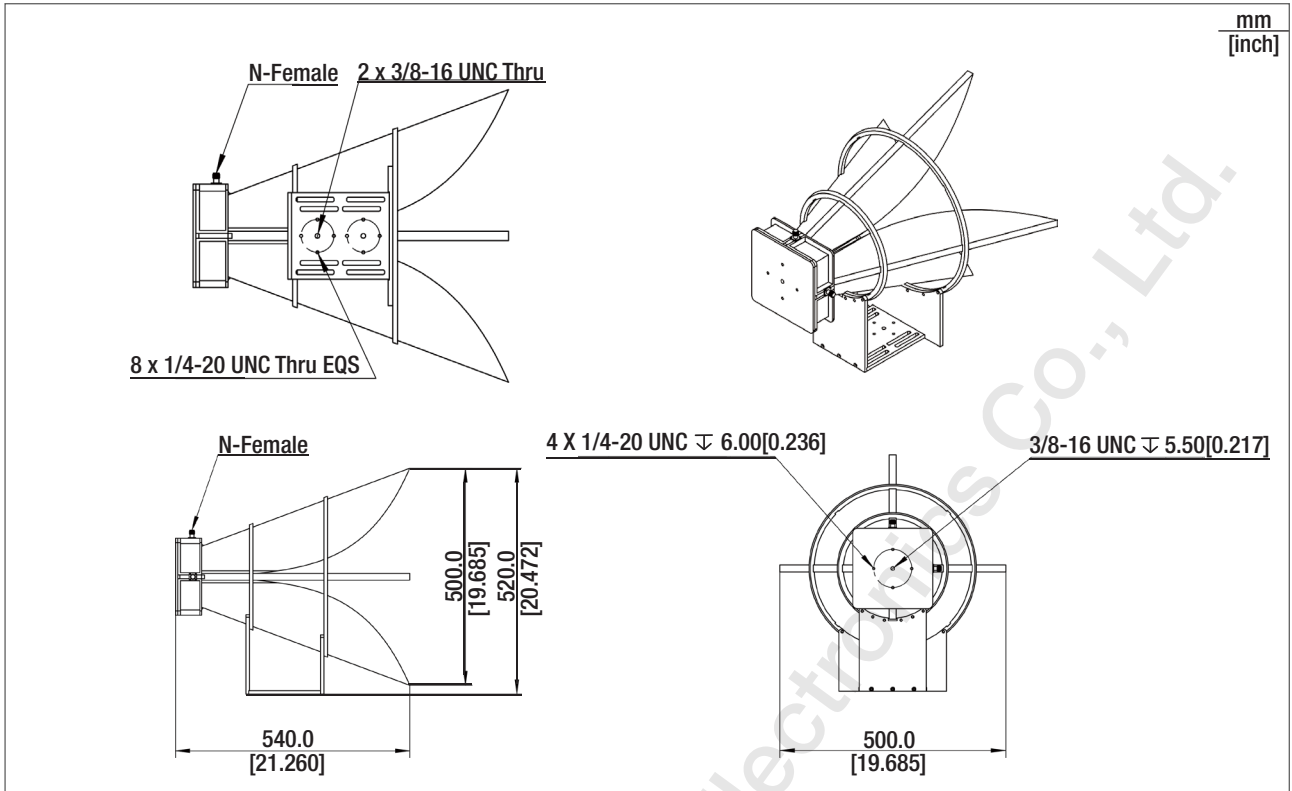

• Dimensional drawing

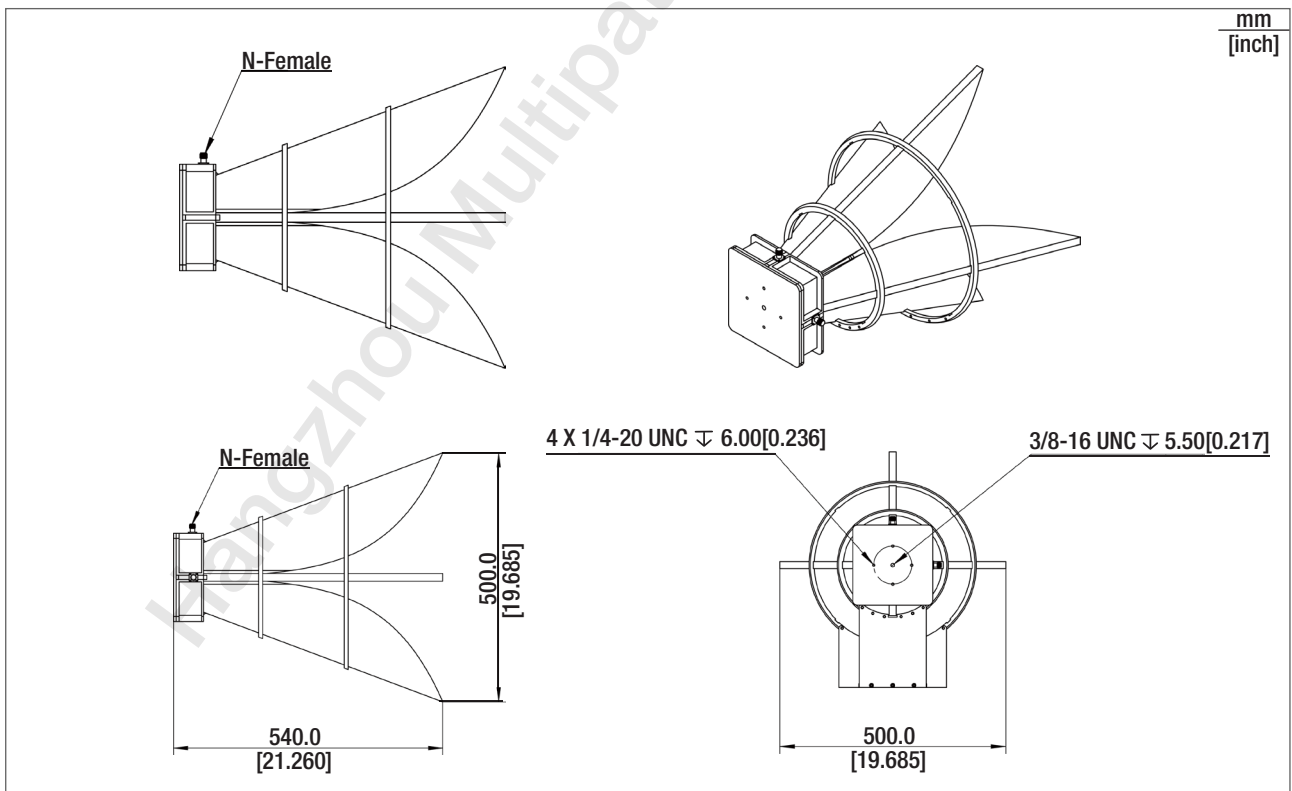

Electrical characteristics

Gain & VSWR & Cross-polarization isolation & S21

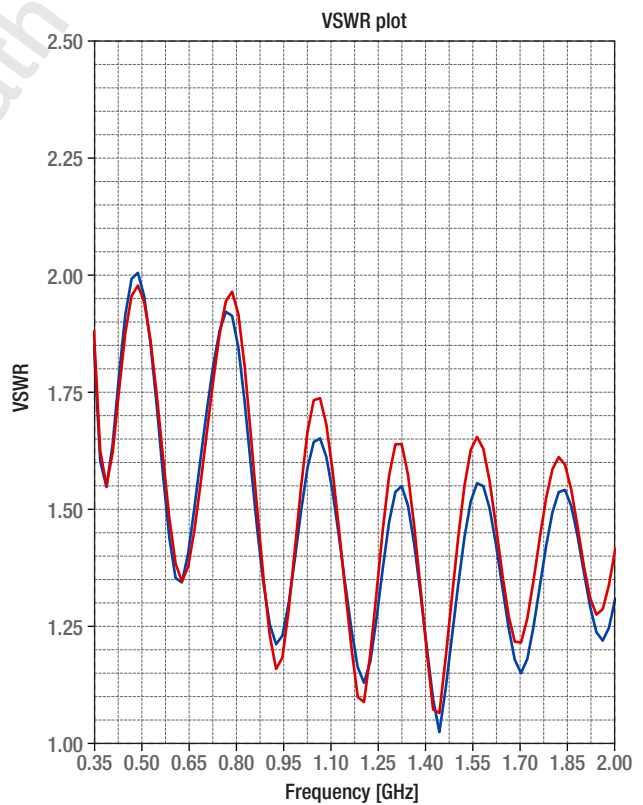
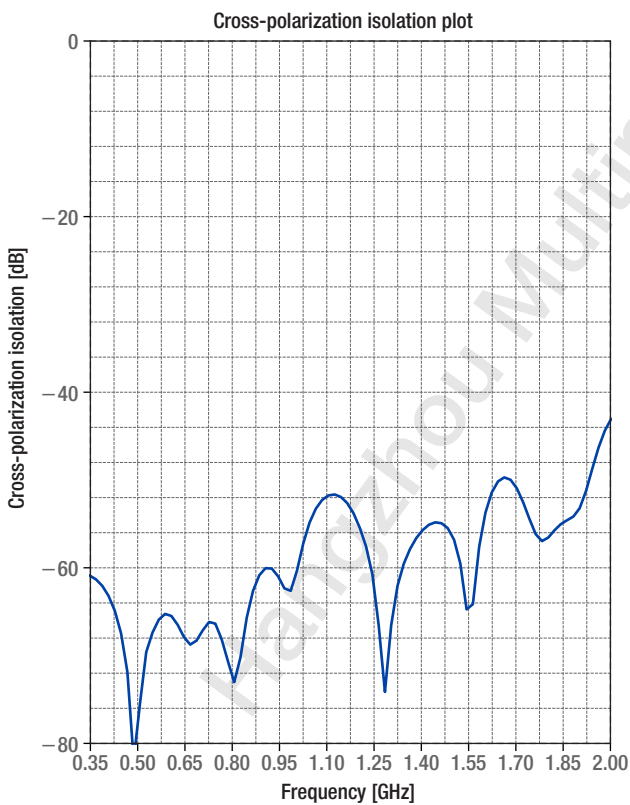
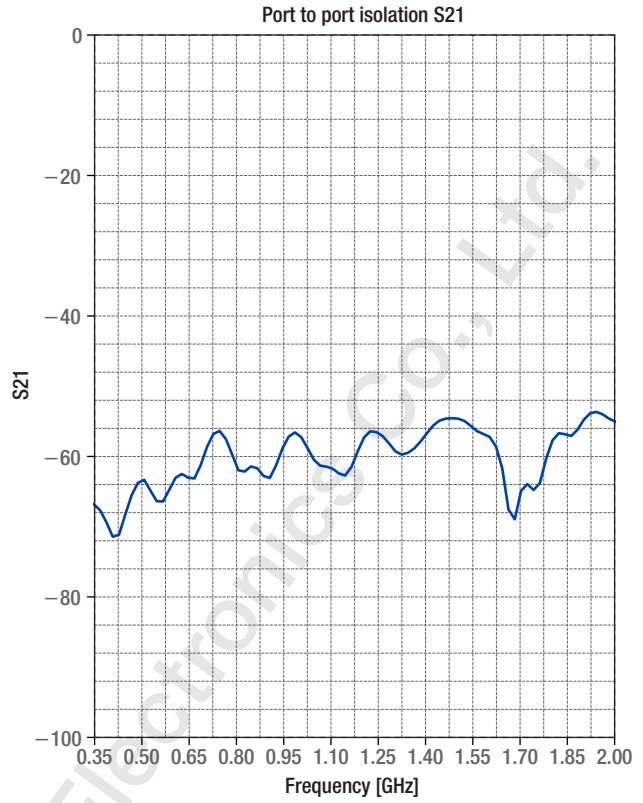
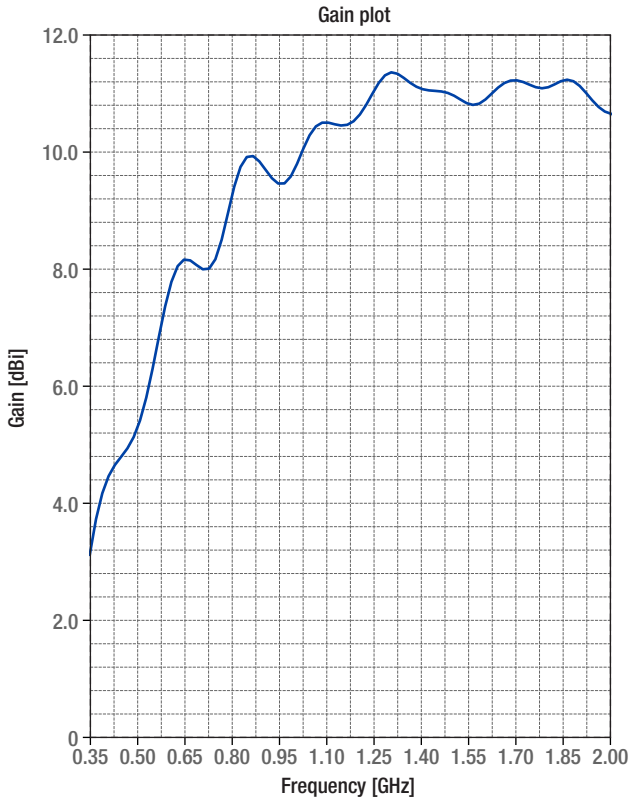

• Radiation patterns

Patterns @ 0.35 GHz

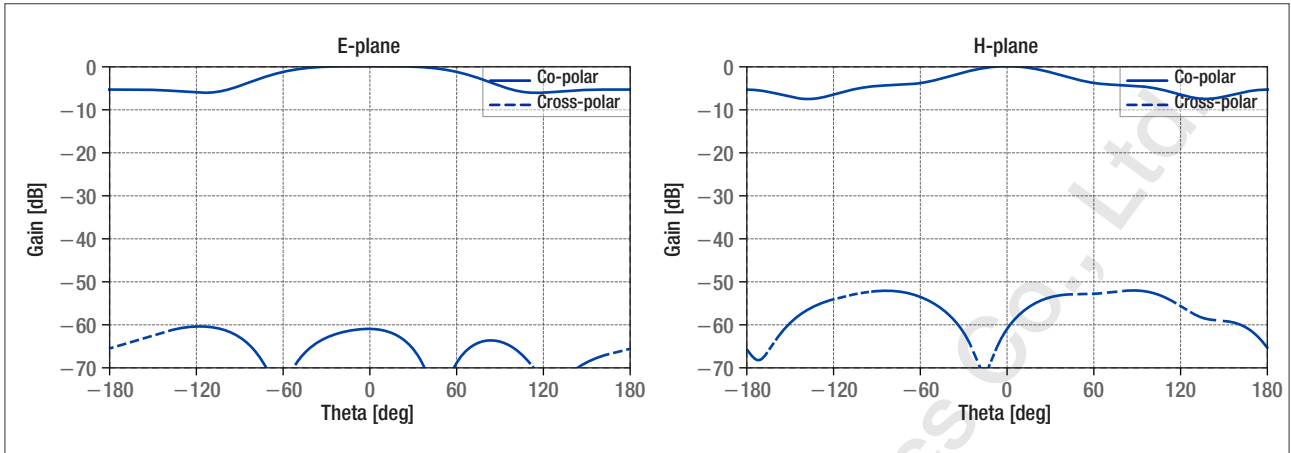

Patterns @ 1.18 GHz

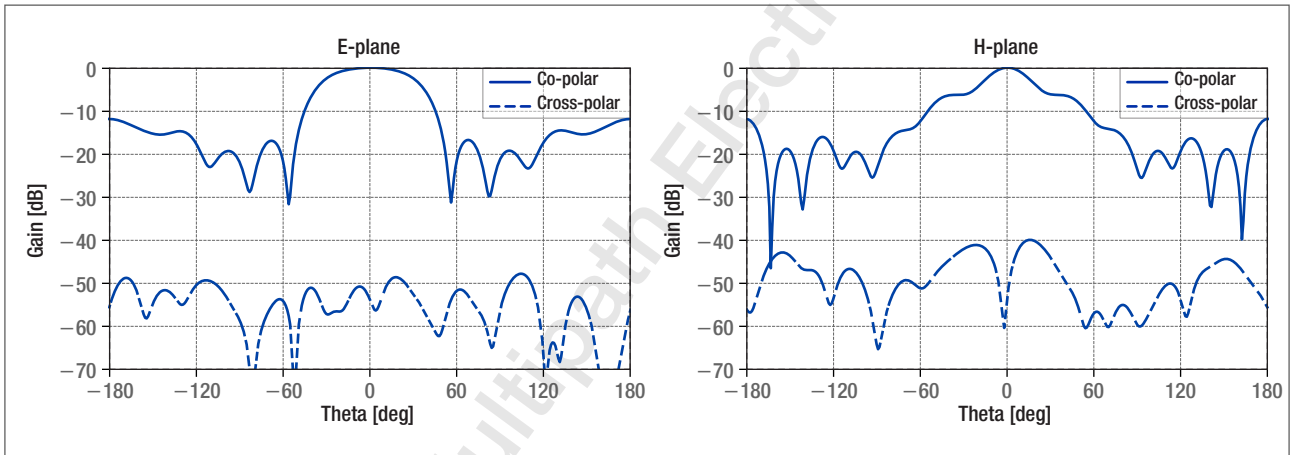

Patterns @ 2.00 GHz

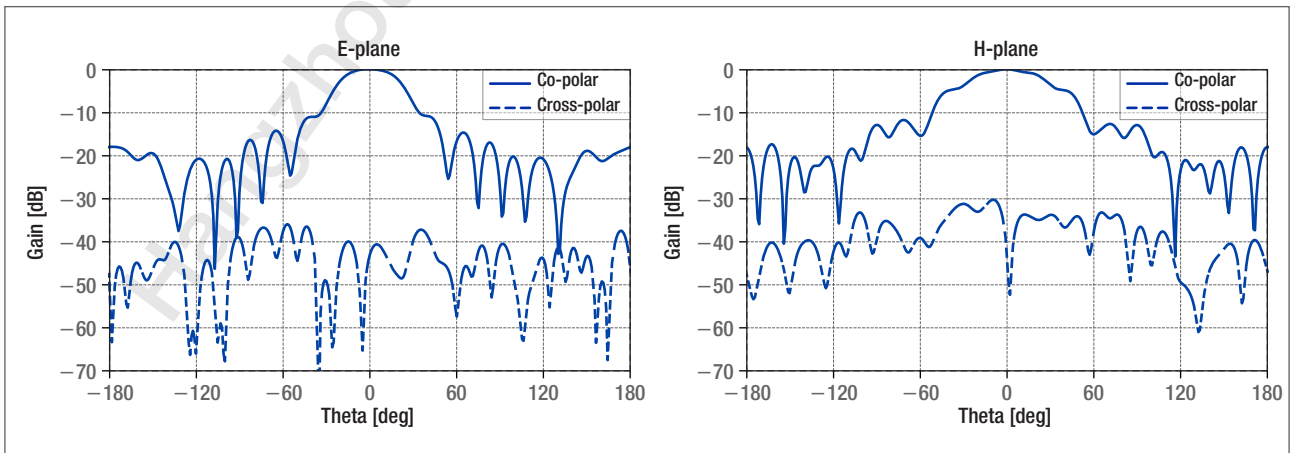

• Data table

Frequency [GHz]	Gain [dBi]	Antenna factor [dB/m]	Cross-polarization isolation [dB]	VSWR		S21
0.35	3.38	17.68	-60.96	1.72	1.75	-67.52
0.50	5.38	18.79	-75.38	1.95	1.94	-63.59
0.65	8.13	18.32	-68.20	1.45	1.41	-63.34
0.80	9.38	18.87	-72.92	1.84	1.92	-62.24
0.95	9.44	20.30	-61.53	1.26	1.23	-58.29
1.10	10.48	20.54	-51.59	1.54	1.58	-62.01
1.25	11.07	21.06	-63.50	1.32	1.39	-57.09
1.40	11.06	22.06	-55.56	1.20	1.19	-56.95
1.55	10.80	23.19	-64.31	1.53	1.64	-56.27
1.70	11.21	23.59	-50.79	1.15	1.21	-65.18
1.85	11.21	24.33	-54.65	1.52	1.57	-57.21
2.00	10.63	25.58	-42.86	1.31	1.41	-55.29

Frequency [GHz]	E-plane, 3dB	H-plane, 3dB beamwidth
0.35	153.94°	93.87°
1.18	63.81°	32.13°
2.00	42.13°	54.55°



Multipath Electronics

Contact

+86-571-56201039

sales@multipath.cn

<https://www.multipath-electron.com>

Technical specifications in this datasheet are subject to change without notice. Actual products may differ from the shown images.